

TECHNICAL DATA SHEET



KRASO® Sealing Insert Type FL | electrogalvanised

Application area

fixed-loose flange with KRASO® Sealing Insert, for installation of media pipes, for buildings with exterior sealing ("black tank") according to DIN 18533. Available in non-corrosive stainless steel V2A or electrogalvanised, each with or without special coating, Torque Control Nut KRASO® DKM | DIN 18533 W1-E and W2.1-E (version "non-pressing water"), W2.2-E (version "pressing water")

Product image



Technical drawing

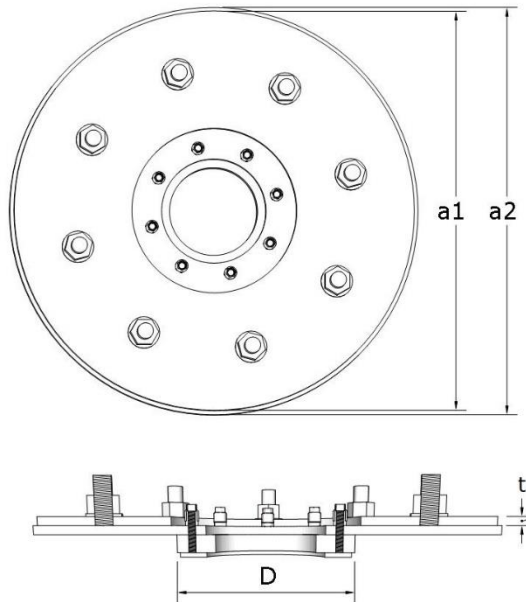

•D | Diameter (mm) •a1 | External diameter fixed flange (mm) •a2 | External diameter loose flange (mm)
 •t | Material thickness (mm) •Weight | in kg

Material

Flange plate	electrogalvanised
Seal	EPDM 40mm (DD) or 20mm (ED)
Supplement	EPDM flat seal 3mm 50 +/- 5 shore
Fixing material	Dowels, bolts, nuts and washers M20 or M12
Nuts	Torque Control Nut KRASO® DKM

Technical details

- Available in non-corrosive stainless steel V2A or V4A or in electrogalvanised steel
- Each as version for pressing (DIN 18533 W2-E) and non pressing water (DIN 18533 W1-E).

Test certificates [In our download area](#)

TECHNICAL DATA SHEET



KRASO® Sealing Insert Type FL | electrogalvanised

Type / Item	KRASO® Sealing Insert Type FL/DD - PRESSING WATER acc. to DIN 18533 W2-E						
D	80	100	125	150	200	250	300
	max. external diameter pipe or cable						
from	0	0	0	0	0	0	0
to	55	75	100	125	175	225	275
a2	400	420	445	470	520	570	620
a1	380	400	425	450	500	550	600
t	10	10	10	10	10	10	10
Weight	22	25	27	29	34	39	44
Item no.	KGVFLDD080	KGVFLDD100	KGVFLDD125	KGVFLDD150	KGVFLDD200	KGVFLDD250	KGVFLDD300

Type / Item	KRASO® Sealing Insert Type FL/ED NON -PRESSING WATER acc. to DIN 18533 W1-E						
D	80	100	125	150	200	250	300
	max. external diameter pipe or cable						
from	0	0	0	0	0	0	0
to	55	75	100	125	175	225	275
a2	220	240	265	290	340	390	440
a1	200	220	245	270	320	370	420
t	6	6	6	6	6	6	6
Weight	8	9,5	10,5	12,5	14	17	200
Item no.	KGVFLED080	KGVFLED100	KGVFLED125	KGVFLED150	KGVFLED200	KGVFLED250	KGVFLED300

•D | Diameter (mm) •a1 | External diameter fixed flange (mm) •a2 | External diameter loose flange (mm)
 •t | Material thickness (mm) •Weight | in kg